

NORTHWEST INDIAN COLLEGE SPACE CENTER

Team RPGs

Flight Readiness Review



Vehicle Dimensions

Length	89.50	Diameter	6.00
Weight	6.75/14.5	Fin Span	22.00
Center of Gravity	50.80/57.77	Center of Pressure	70.33
Static Stability	3.20/2.06		

Length: 89.5000 In. , Diameter: 6.1600 In. , Span diameter: 22.1600 In.
 Mass 9.512492 Lb. , Selected stage mass 9.512492 Lb.
 CG: 50.8060 In., CP: 70.3330 In., Margin: 3.20 Overstable
 Shown without engines.

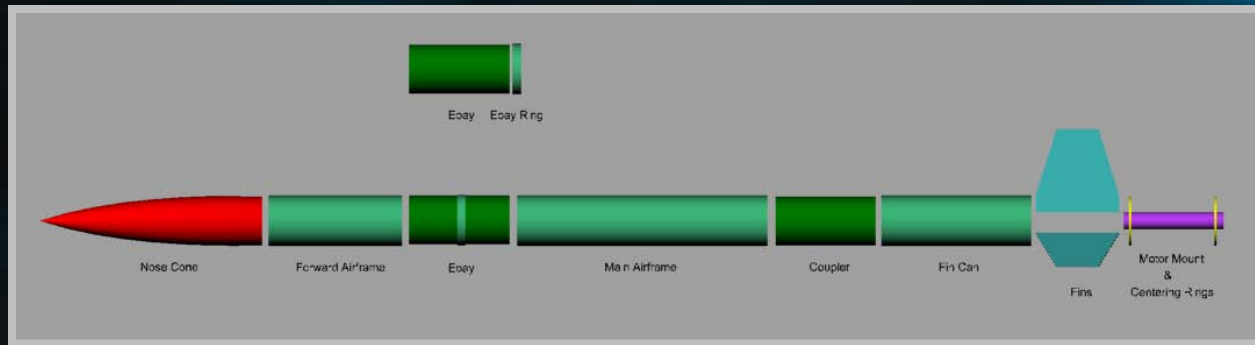
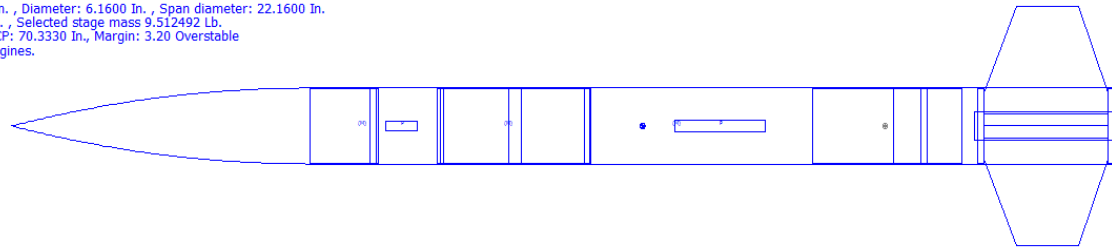

Launch Vehicle Key Design Features

1. The rocket is designed to be as light as possible while maintaining a strength-to-weight ratio sufficient for mission success and safety.
2. Carry and Deploy a quadcopter (MV) to tow the Salish Star back to the launch area.
3. Two onboard HD cameras, one pointing up and one pointing down.

Motor Description

Cesaroni Technology Incorporated (CTI) Pro54 K445 Classic

- Motor has enough thrust to get the rocket safely off the launch rail.
- Motor has enough thrust to achieve the predicted altitude.

Static Stability Margin

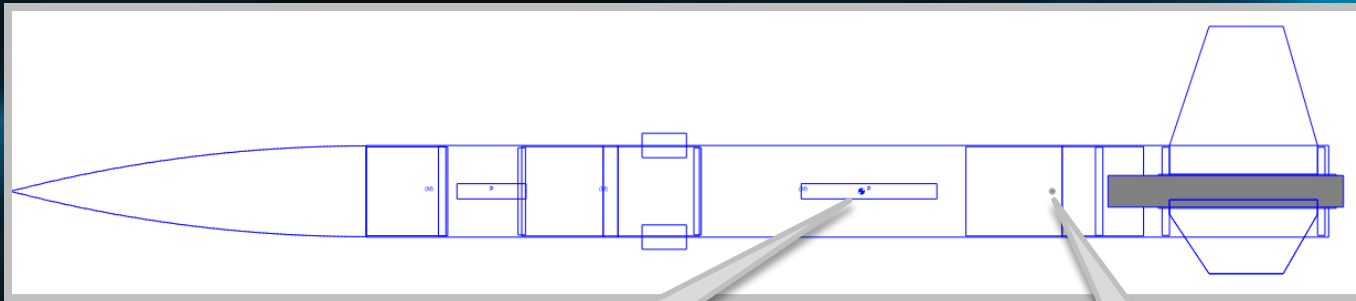

Center of Gravity
57.44"

Center of Pressure
70.33"

Center of Pressure 70.33"
Center of Gravity 57.44"
Diameter 6.00"
Static Stability 2.11

Stability Margin
2.09 with motor

$$\text{Stability Margin} = (\text{CP} - \text{CG}) / \text{Diameter}$$

Thrust-to-Weight Ratio

Thrust to Weight Ratio = Pounds of Thrust/Weight of Salish Star

Motor	Max Thrust	Load Weight	Ratio
K445	149.453	15.3	10:1

Minimum of 5:1 is recommended

Mass Statement and Margin

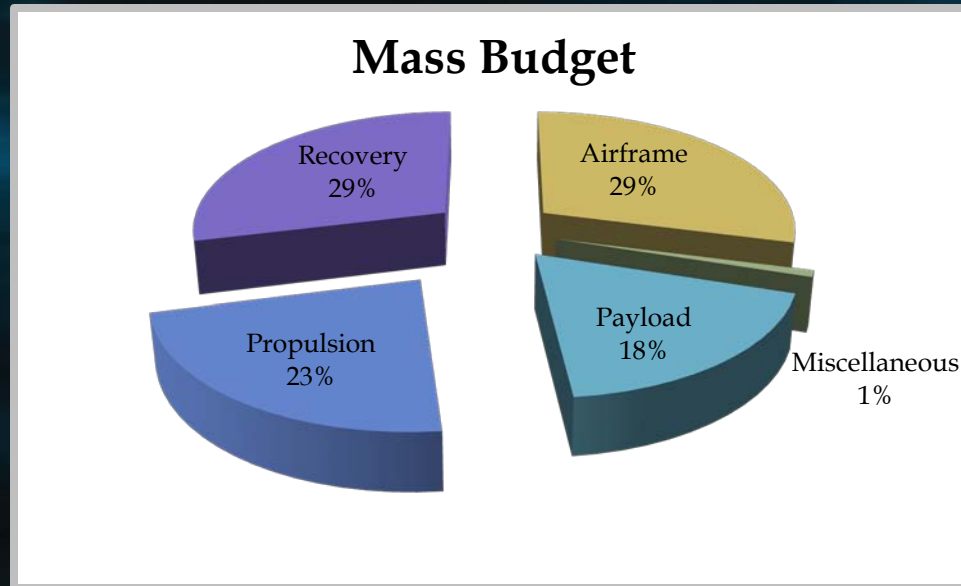

The selected motor has reserve power for up to 13 extra pounds and still deliver a safe liftoff and flight.

Parachute Sizes & Descent Rates

- Parachute: Main: 52"
- Parachute: Drogue: 28"
- Main Recovery harnesses – 1/2" Tubular Kevlar
- Drogue Recovery harnesses – 1/2" Tubular Kevlar
- Drogue harness - 24 feet long.
- Main harness - 24 feet long.
- Descent Rate under Drogue – 59.41 ft/s
- Descent Rate under Main – 21.27 ft/s

Kinetic Energy

Drogue Parachute				
Manufacturer/Model		SkyAngle		
Size		28		
Altitude at Deployment (ft)		5,280		
Velocity at Deployment (ft/s)		0.0024		
Terminal Velocity (ft/s)		59.41		
Recovery Harness Material		Kevlar		
Harness Size/Thickness (in)		1/8"		
Recovery Harness Length (ft)		24		
Harness/Airframe Interfaces		1/8" Kevlar Loops		
Kinetic Energy During Descent (ft-lb)	Section 1	Section 2	Section 3	Section 4
	417	64	324	

Main Parachute				
Manufacturer/Model		Top Flite		
Size		52		
Altitude at Deployment (ft)		800		
Velocity at Deployment (ft/s)		59.41		
Landing Velocity (ft/s)		21.27		
Recovery Harness Material		Kevlar		
Harness Size/Thickness (in)		1/8"		
Recovery Harness Length (ft)		24		
Harness/Airframe Interfaces		1/8" Kevlar Loops		
Kinetic Energy Upon Landing (ft-lb)	Section 1	Section 2	Section 3	Section 4
	67	10	52	

Predicted Altitude

Latitude: 34° 38' 50" N

Relative humidity: 77 %

Longitude: 86° 33' 11" W

Temperature: 65 Deg. F

Elevation: 827 feet

Pressure: 30.27 In.

Wind Speed is Constant

Distances are in Feet	Wind Speed (Kts)				
	0-2	3-7	8-14	15-25	20-30
Rail Angle at 0°	159	174	614	735	1,329
Altitude	3,044	3,044	2,935	2,924	2,831

Test Plans and Procedures

Safety Officer – Trisha is responsible for ensuring that all safety procedures, regulations, and risk assessments are followed.

The Northwest Indian College Space Center has a 5000 foot waiver from the US and the Canadian aviation agencies. We can launch our rockets from 0900 to 1300 on Friday, Saturday or Sunday.

Safety Rules and Regulations
Potential Failure Modes and Mitigation

Test Flight

Date	Motor	Purpose	Success	Result
1/3	CTI I287	Recovery Test	80%	Ejection Charge Gas Leak
2/17	CTI J240	Recovery Test	70%	Recovery Harness Separation
3/3	CTI J240	Recovery Test	100%	Successful Deployment
3/9	CTI J760	MV Deployment Test	100%	MV Deployed Successfully

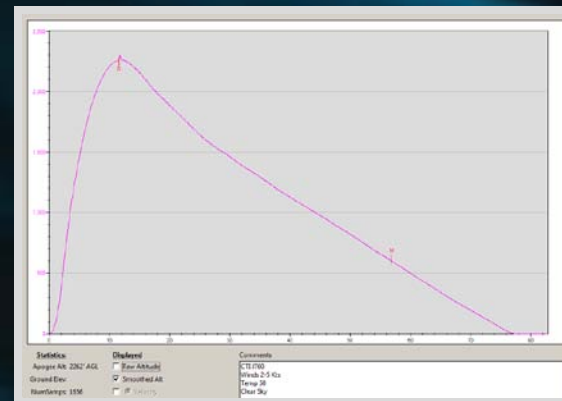
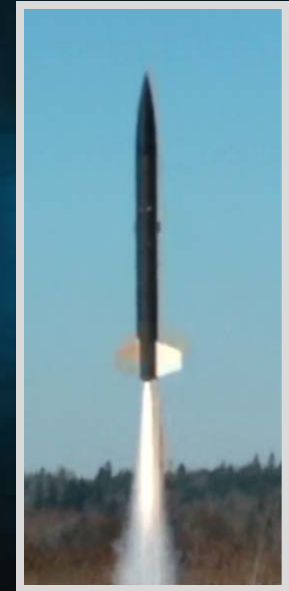

Recovery System Test

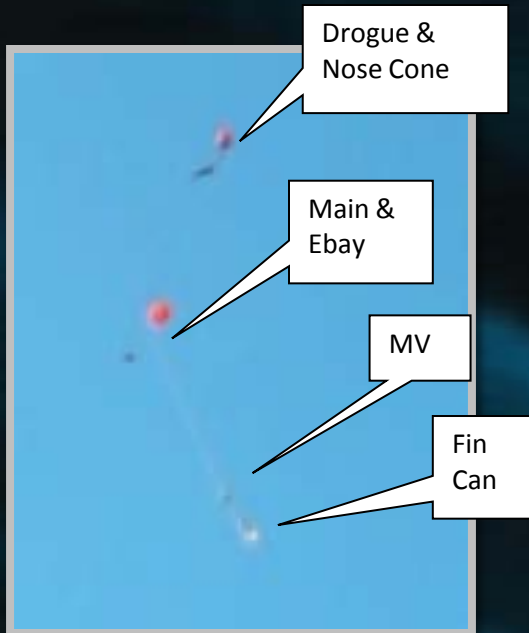

Blackpowder ground tests were satisfactory

Launch Vehicle Verification

- Ground Tests
- Simulation Examinations
- Visual Inspections
- NAR Mentor Inspections
- Test Flights
- Data Analysis

Test Plan Overview

- Black Powder Ground Tests
- Avionics Inspection and Tests
- Visual Inspections
- NAR Mentor Inspections
- Scheduled Test Flights
- Data Analysis

Payload Design

	Diameter In.	Height In.
Folded	5.75	26.00
Extended	18.00	6.00

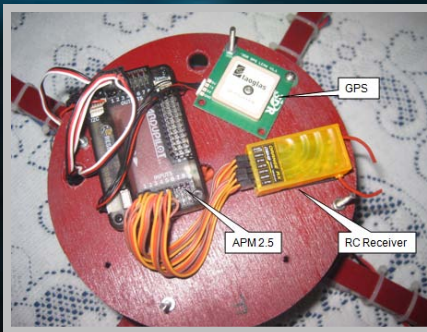

Primary Electronics



Mini-Mincer MV



Folded View



Final Payload Design Overview

System	Subsystem	Evaluation	Verification
Fuselage	Body	Construction	Test Flights
	Arms	Inspection	
Propulsion	Motors	Thrust Tests	
	ESC	Voltage tests	
	Propellers	Balancing	
Electronics	Batteries	Voltage check	
	Flight Controller	Bench testing	
	Autopilot	Bench testing	
Tow Harness	Upper Section	Ground and air testing	
	Lower Section		
	Connecting quicklinks		
RC Equipment	Transmitter and Receiver	Ground and air testing	

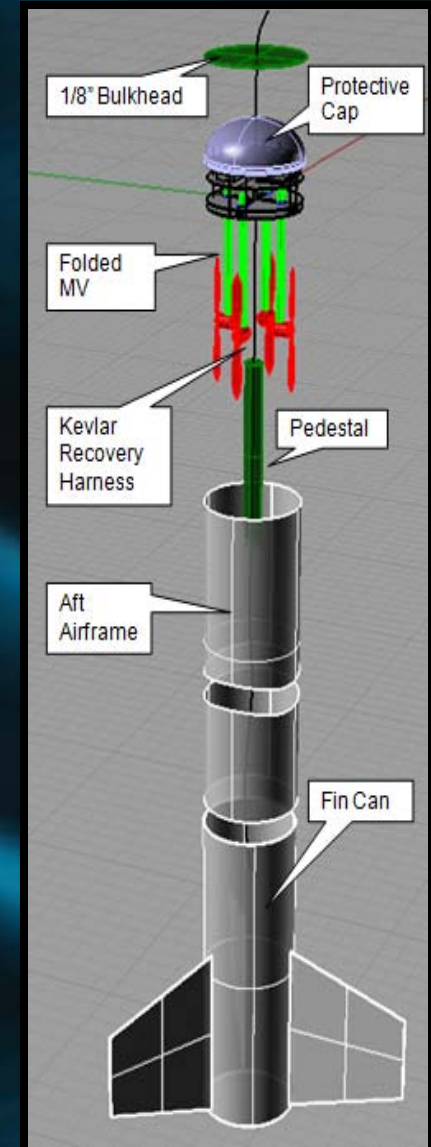

Payload Test & Verification

Feature	Verification Plan	Status
Construct MV fuselage	Inspection	Complete
Arm folding	Inspection	Complete
Motor thrust testing	Bench test	Complete
Propeller balancing	Bench test	Complete
Flight controller construction	Inspection	Complete
Flight controller testing	Bench test	Complete
Autopilot construction	Inspection	Complete
Autopilot testing	Bench test	Work in progress
RC Testing	Flight tests	Work in progress

Payload Test Plan

- Test each component as it's built
- Gather baseline data for each component
- Integrate one component at a time and verify it's functioning satisfactorily
- Ground test entire system
- Flight test payload

Payload Integration

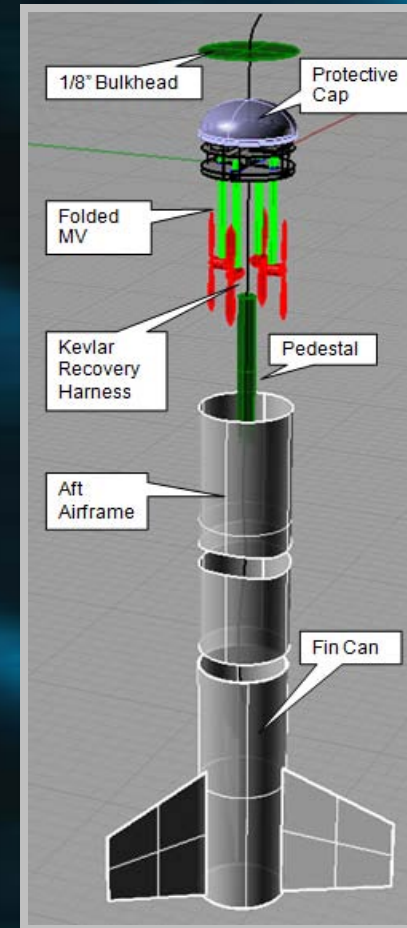

Interfaces with Ground Systems

1. Radio Control
2. GPS
3. 3DR Radio Telemetry
4. FPV Camera

Requirements Verification Status

Requirement	Design Feature	Verification	Status
2. The launch vehicle shall deliver the science or engineering payload to, but not exceeding, an altitude of 5,280 feet. above ground level (AGL). One point will be deducted for each foot achieved below the target altitude. Two points will be deducted for each foot achieved above the target altitude. Any team whose vehicle travels over 5,600 ft. according to their competition altimeter will be disqualified from being able to receive the overall competition award and will receive a score of zero for the altitude portion of their total score.	Design through Rocksim 9, Power Management System	Test	Work in Progress
a. The official, marked altimeter is damaged and/or does not report an altitude after the team's competition flight.	Safe Recovery will preclude this	Inspection	Work in Progress
b. The team does not report to the NASA official designated to record the altitude with their official marked altimeter by 5:00 pm on the day of the launch.	Check list will preclude this		Work in Progress
11. The launch vehicle shall be capable of being prepared for flight at the launch site within 2 hours, from the time the waiver opens.	Designed as required	Check lists	Work in Progress
12. The launch vehicle shall be capable of remaining in launch-ready configuration at the pad for a minimum of 1 hour without losing the functionality of any onboard component.	Battery power calculated to last at least 2 hrs for each device using a battery	Simulation analysis	Work in Progress
15. Data from the science or engineering payload shall be collected, analyzed, and reported by the team following the scientific method.	Data analysis will be examined post flight	Testing will follow payload completion prior to the competition flight	Work in Progress
18. The total impulse provided by the launch vehicle shall not exceed 5,120 Newton-seconds (L-class). This total impulse constraint is applicable to any combination of one or more motors.	Designed as required, L motor largest permissible	Inspection	Complete

Requirements Verification Status

19. All teams shall successfully launch and recover their full scale rocket prior to FRR in its final flight configuration.			
a. The purpose of the full scale demonstration flight is to demonstrate the launch vehicle's stability, structural integrity, recovery systems, and the team's ability to prepare the launch vehicle for flight.	Test flights scheduled prior to FRR	Test flight	Complete
b. The vehicle and recovery system shall have functioned as designed.	Extensive ground testing where possible, test flights for the vehicle		Complete
c. The payload does not have to be flown during the full-scale test flight.			Flown Successfully

Requirements Verification Status

e. The success of the full scale demonstration flight shall be documented on the flight certification form, by a Level 2 NAR/TRA observer.	Our mentor and 2 other NAR L2 individuals are available	Test flight	Complete
f. After successfully completing the full-scale demonstration flight, the launch vehicle or any of its components shall not be modified without the concurrence of the NASA Range Safety Officer.	No changes will be made.		Complete
22. Students on the team shall do 100% of the work on the project, including design, construction, written reports, presentations, and flight preparation with the exception of assembling the motors and handling black powder charges.	Implemented as required	Inspection	Work in Progress
24. The maximum amount teams may spend on the rocket and payload is \$5000 total. The cost is for the competition rocket as it sits on the pad, including all purchased components and materials and the fair market value of all donated components and materials. The following items may be omitted from the total cost of the vehicle:			Complete